

F100-2IOL F100 Ethernet

Axial coupler

Inductive Coupling Systems

■ Ordering overview flange

Standard flange

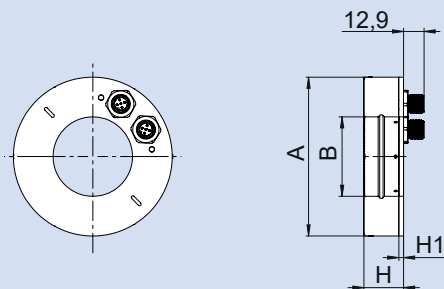

Type	F100-2IOL		F100 Ethernet	
	IC-Base-F100-2IOL D100/050	IC-Remote-F100-2IOL D100/050	IC-Base-F100-ETH D100/050	IC-Remote-F100-ETH D100/050
Id.-No.	0E012330	0E012331	0E011420	0E011421
A	100			
B	50			
B1	-			
B2	-			
H	25			
H1	3			
Weight	0.26 kg			

Outer flange with feed-through

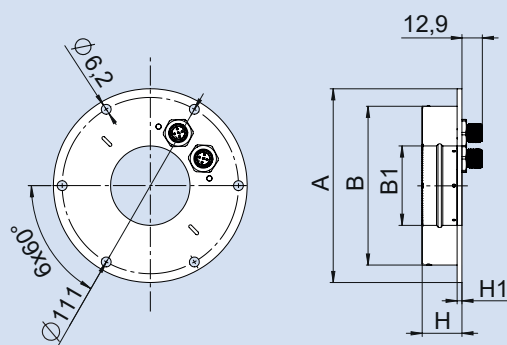

Type	F100-2IOL		F100 Ethernet	
	IC-Base F100-2IOL D122/050	IC-Remote-F100-2IOL D122/050	IC-Base F100-ETH D122/050	IC-Remote-F100-ETH D122/050
Id.-No.	0E012332	0E012333	0E012320	0E012321
A	122			
B	100			
B1	50			
B2	-			
H	25			
H1	3			
Weight	0.36 kg			

Inner flange with feed-through

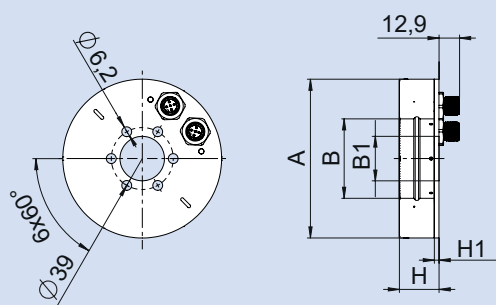

Type	F100-2IOL		F100 Ethernet	
	IC-Base F100-2IOL D100/028	IC-Remote-F100-2IOL D100/028	IC-Base F100-ETH D100/028	IC-Remote-F100-ETH D100/028
Id.-No.	0E012334	0E012335	0E012322	0E012323
A	100			
B	50			
B1	28			
B2	-			
H	25			
H1	3			
Weight	0.34 kg			

Flangering with feed-through

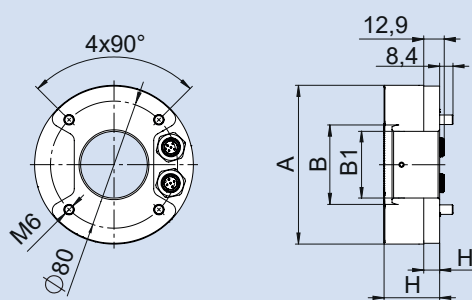

Type	F100-2IOL		F100 Ethernet	
	IC-Base F100-2IOL D100/042	IC-Remote-F100-2IOL D100/042	IC-Base F100-ETH D100/042	IC-Remote-F100-ETH D100/042
Id.-No.	0E012336	0E012337	0E012324	0E012325
A	100			
B	50			
B1	42			
B2	-			
H	25			
H1	10			
Weight	0.48 kg			

FURTHER OPTIONS AVAILABLE ON REQUEST!

- Outer flange without feed-through
- Inner flange without feed-through
- Threaded sleeve with without feed-through