

### Application/customer benefits

- Contact free, safe transmission of energy and signals between moving / rotating and stationary components
- Application examples: Supply of sensors, Supply and monitoring of remote systems
- Dynamic Pairing
- Wear and maintenance free
- Protective function: Temperature monitoring, foreign object detection, reverse polarity protection
- Multi-level LED with good visibility

### Technical features

- Mounting: M30 x 1.5
- Operating voltage: 24 V (18 ... 30 V)
- Transmission distance: 0 - 10 mm
- Transmission of energy: 24 V / 12 W (500 mA) with a distance of 0 - 7 mm
- Transmission of signals: IO-Link (COM1, COM2, COM3), 1 digital signal
- Connection: Base male connector M12 x 1 (5-pin), remote female connector M12 x 1 (5-pin)
- Protection class: IP67

### Standard equipment

Inductive coupler Base or Remote

### Block diagram

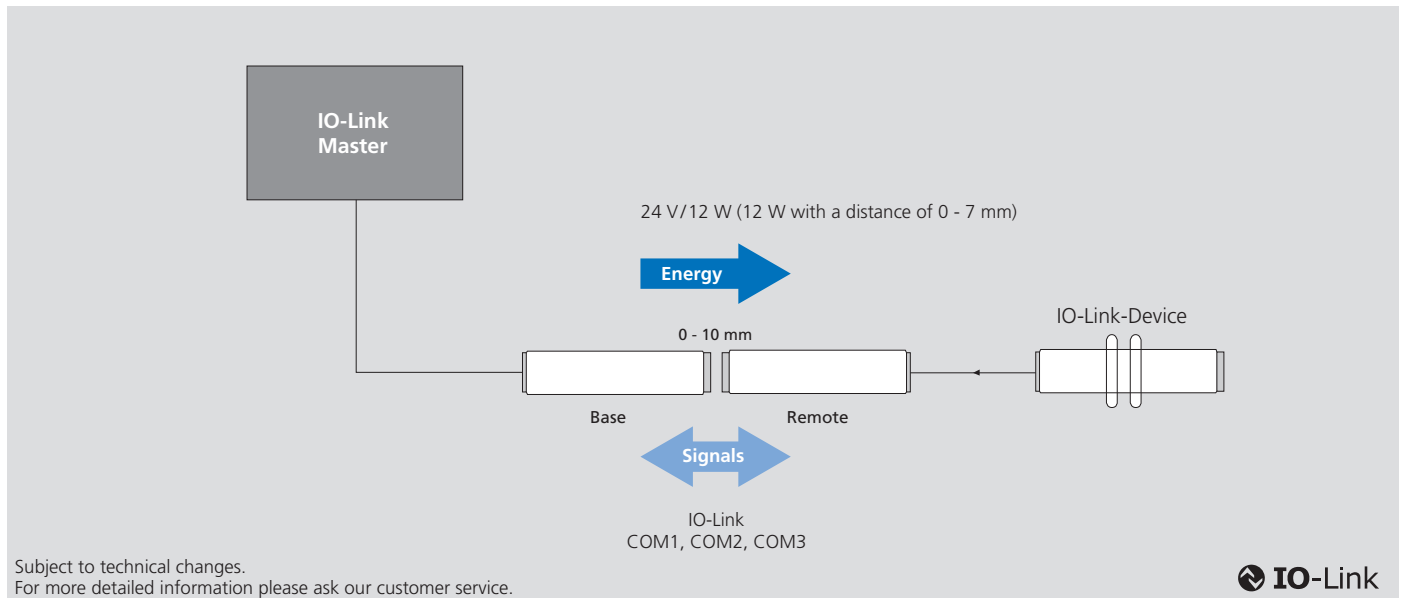

LED Function display Base	
<b>LED Power</b>	
<b>Color</b>	Green/red
<b>Function</b>	Off green » Unit not supplied with voltage
	Flashes green for 3 s/0.5 s » Device supplied with voltage 18 V < U < 30 V
	On green » Voltage ok and mobile unit detected
	Flashes 2 Hz red/green » Alternately U in > 30 V, remote overload
	Flashes 2 Hz red » Base overtemperature
<b>LED Signal 1</b>	Flashes red for 3 s/0.5 s » Foreign object detected
	<b>LED Signal 1</b>
<b>Color</b>	Yellow/red
<b>Function</b>	Off yellow » No mobile unit detected
	On yellow » Mobile unit detected, no IOL mode
	Flashes 900 ms/100 ms yellow » IOL mode (COM1, COM2, COM3)
<b>LED Signal 2</b>	2 Hz red » Signal overload (C/Q, DO, DAV)
	<b>Color</b>
<b>Function</b>	Off yellow » Digital channel not switched (low)
	On yellow » Digital channel switched (high)
<b>Data Valid Output</b>	
<b>Function</b>	ON » Handset has been recognized and there is no error
	OFF » The data at the output is not valid because the mobile unit is not recognized, overload at the output, mobil unit power supply overloaded.

LED Function display Remote	
<b>LED Coupling</b>	
<b>Color</b>	Green/red
<b>Function</b>	Off green » Device is not coupled
	On green » Device is coupled and 24 V out ok
	2 Hz red/green » Overload at 24 V out or insufficient power supply
	2 Hz red » Overtemperature
<b>LED IO-Link</b>	2 Hz rot » Overload cut-off at 24 V out
	<b>Color</b>
<b>Function</b>	Off yellow » No stationary part detected
	On yellow » Stationary part detected, no IOL mode
	Flashes 900 ms/100 ms yellow » IOL mode (COM1, COM2, COM3)
<b>LED Signal</b>	2 Hz red » Signal overload (C/Q)
	<b>Color</b>
<b>Function</b>	Off yellow » Digital channel not switched (low)
	On yellow » Digital channel switched (high)

# Inductive Coupling System

# M30-IOL

- Stationary Unit - Base
- Mobile Unit - Remote

Axial coupler

## Base / Remote

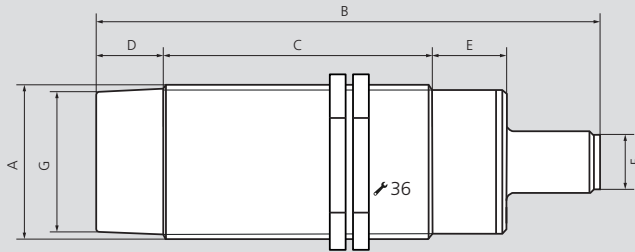

Display Base LED

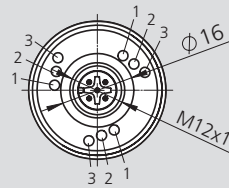

Base

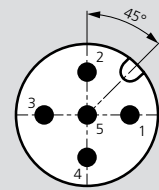

Male connector 5-pin  
M12 x 1

Display Remote LED

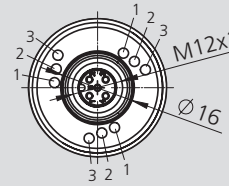

Remote

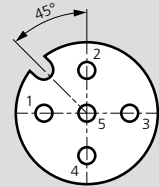

Female connector 4-pin  
M12 x 1

Number	LED	Color
1	Power LED	Green / Red
2	Signal LED	Yellow
3	IOL LED	Yellow / Red

Subject to technical changes.  
For more detailed information please ask our customer service.

## Inductive coupling system M30-IOL

Type		Base	Remote	
Id. No.		0E011604	0E011605	
A	mm	M30 x 1.5		
B	mm	96	94	
C	mm	52		
D	mm	13		
E	mm	18		
F	mm	M12 x 1 / Male	M12 x 1 / Female	
G	mm	Ø 27		
<b>Housing material</b>		CrNi, PA66, PC GF30%		
<b>Protection class</b>		IP67		
<b>Operating temperature</b>		-20°C ... +50°C		
<b>Storage temperature</b>		-20°C ... +80°C		
<b>Transmission distance</b>		0 mm ... 10 mm (12 W: 0 mm ... 7mm)*		
<b>Weight</b>	kg	0.13	0.13	
Operating voltage		24 V (18 ... 30 V)	-	
Output voltage		-	24 V ± 10% DC	
Power consumption (Base)		1500 mA	-	
Power output (Remote)		-	500 mA	
Overload protection / short circuit protection		✓	✓	
Residual ripple		-	< 200 mV	
Reverse polarity protection		✓	-	
Temperature monitoring		✓	✓	
Data-Valid Output		150 mA	-	
Ready delay		< 600 ms		
PIN assignment		PIN	Signal Base	Signal Remote
Supply voltage		1	24 V IN	24 V OUT
Digital signal		2	0/24 V OUT	0/24 V IN
Ground		3	GND	GND
IO-Link Signal		4	IO-Link CQ	IO-Link CQ
Data-Valid		5	DAV 24 V	-

\* V in ≥ 22 V Base